

ICS 67.040
X 04



中华人民共和国国家标准

GB/T 12529.4—2008
代替 GB/T 12529.4—1990

粮油工业用图形符号、代号 第 4 部分：油脂工业

Graphic symbols and codes for grain and oils industry—
Part 4: Oils and fats industry

2008-11-04 发布

2009-01-20 实施

中华人民共和国国家质量监督检验检疫总局
中国国家标准化管理委员会 发布

前 言

GB/T 12529《粮油工业用图形符号、代号》分为五个部分：

- 第 1 部分：通用部分；
- 第 2 部分：碾米工业；
- 第 3 部分：制粉工业；
- 第 4 部分：油脂工业；
- 第 5 部分：仓储工业。

本部分是 GB/T 12529 的第 4 部分。

本部分是对 GB/T 12529.4—1990《粮油工业用图形符号、代号 油脂工业》的修订。

本部分与 GB/T 12529.4—1990 的主要技术差异如下：

- 将原标准中剥壳分离破碎(Y101~Y104)、轧胚蒸炒(Y201~Y207)、榨油(Y301~Y305)合并，全部归入预处理榨油(Y101~Y133)；
- 增加了立式干燥机、大豆调质塔、大豆皮仁分离器等 39 项；
- 取消了平面回转筛、氢化反应罐、道生气体等 15 项；
- 规范了原标准中部分名词术语，如：“蒸烘机”改为“蒸脱机”等。

本部分自实施之日起，代替 GB/T 12529.4—1990。

本部分由国家粮食局提出。

本部分由全国粮油标准化技术委员会归口。

本部分起草单位：国家粮食储备局西安油脂科学研究设计院、武汉工业学院。

本部分主要起草人：柏云爱、冉萍、杜宣利、郑晓、林国祥、关源泉、林正军。

本部分所代替标准的历次版本发布情况为：

- GB/T 12529.4—1990。

粮油工业用图形符号、代号

第 4 部分：油脂工业

1 范围

GB/T 12529 的本部分规定了油脂制备工业工艺流程图用的图形符号。

本部分适用于粮油行业生产、科研、设计、教学及其他有关领域。

本部分不规定工艺流程图中一般不作表达的项目以及已列入 GB/T 12529.1 的项目。

2 规范性引用文件

下列文件中的条款通过 GB/T 12529 的本部分的引用而成为本部分的条款。凡是注日期的引用文件，其随后所有的修改单(不包括勘误的内容)或修订版均不适用于本部分，然而，鼓励根据本部分达成协议的各方研究是否可使用这些文件的最新版本。凡是不注日期的引用文件，其最新版本适用于本部分。

GB/T 4270 技术文件用热工图形符号与文字代号

GB/T 4457.4 机械制图 图样画法 图线

GB/T 4728(所有部分) 电气简图用图形符号

GB/T 6567(所有部分) 技术制图 管路系统的图形符号

GB/T 12529.1 粮油工业用图形符号、代号 第 1 部分：通用部分

3 一般规定

- 3.1 本部分规定的图形符号涉及油脂制备生产线的各个环节。
- 3.2 本部分规定的图形符号在工艺流程图中应用时，可按实际需要进行缩放。
- 3.3 本部分规定的图形，允许反方向绘制。
- 3.4 本部分规定的图形符号的图线，执行 GB/T 4457.4 的有关规定。
- 3.5 油脂工业用管路管件等的图形符号，除本标准规定者外，执行 GB/T 6567(所有部分)的有关规定。
- 3.6 本部分及 GB/T 12529.1 均未规定的符号，按有关的国家标准或行业标准执行；国家标准及行业标准未作规定时，可遵循简单明了、反映实物主要特征的原则，自行绘制。
- 3.7 本部分按照粮食行业对专业分类赋予各专业相应代号，代号用专业名称中反映特征的一个字母表示，字母用大写。各专业代号为：通用 T；碾米 M；制粉 F；油脂 Y；仓储 C。

4 分类

- 4.1 预处理榨油：Y101～Y133。
- 4.2 浸出：Y201～Y230。
- 4.3 精炼：Y301～Y341。
- 4.4 其他：Y401～Y404。
- 4.5 棕榈油：Y501～Y510。
- 4.6 管路管件：Y601～Y635。
- 4.7 物料：Y701～Y731。

5 图形符号

图形符号见表 1。

表 1

编 号	图形符号	中、英文名称	备 注
Y101		喂料器 feeder	
Y102		圆筒打筛 hull beater	
Y103		多联打筛 multiple hull beater	
Y104		吸风平筛 aspirated plan sifter	
Y105		水洗机 washing machine	
Y106		胶辊磨泥机 rubber roll soil bit mill	
Y107		离心打泥机 centrifugal soil bit impactor	

表 1 (续)

编 号	图形符号	中、英文名称	备 注
Y108		圆盘剥壳机 disc huller	
Y109		刀板剥壳机 bar huller	
Y110		离心剥壳机 centrifugal decorticator	
Y111		刀笼剥壳机 bar-cage decorticator	

表 1 (续)

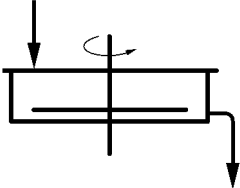
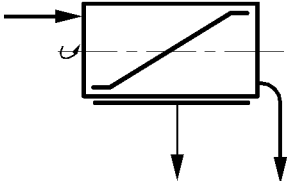
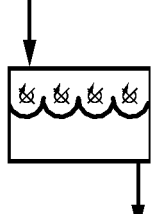
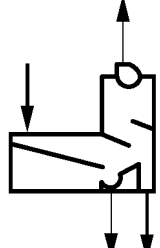
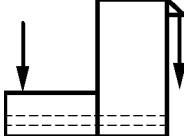
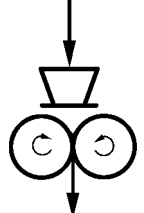
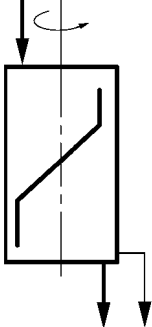

编 号	图形符号	中、英文名称	备 注
Y112		籽壳分离机 hull and seed separator	
Y113		齿辊破碎机 toothed cracking roll (one pair) 齿辊剥壳机 toothed decorticator	
Y114		双对辊齿辊破碎机 toothed cracking roll (two pair)	
Y115		锤式破碎机 hammer cracker	

表 1 (续)

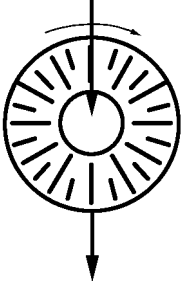
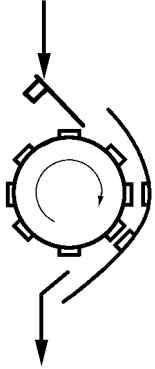
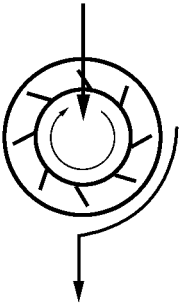
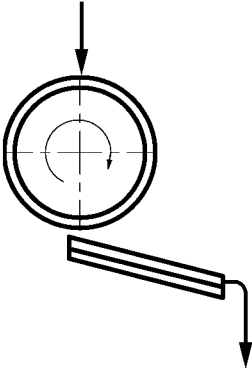
编 号	图 形 符 号	中、英文名称	备 注
Y116		蛟龙式壳仁分离筛/螺旋筛 auger kernel husk separator	
Y117		立式干燥机 vertical dryer	
Y118		大豆调质塔 soybean conditioning tower	
Y119		大豆皮仁分离器 soybean hull seperator	

表 1 (续)

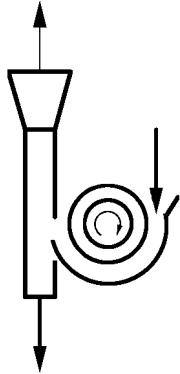
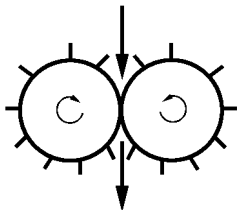
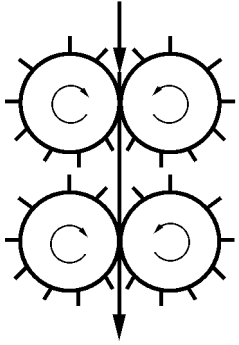
编 号	图形符号	中、英文名称	备 注
Y120		平板烘干机 chain dryer	
Y121		对辊轧坯机 paired flaking roll	
Y122		双对辊轧坯机 two-pair flaking roll	
Y123		三辊轧坯机 triple-flaking roll	

表 1 (续)

编 号	图 形 符 号	中、英文名称	备 注
Y124		卧式软化锅 horizontal conditioner 卧式蒸炒锅 horizontal cooker	
Y125		立式软化锅 conditioner	
Y126		立式蒸炒锅 vertical stack cooker	
Y127		油料膨化机 oil seed expander	

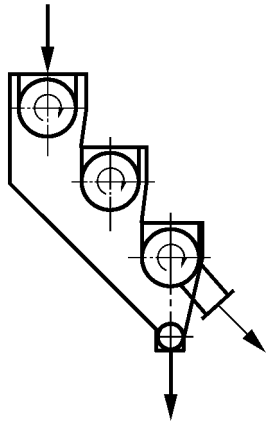
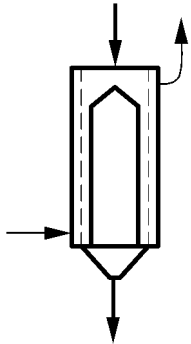
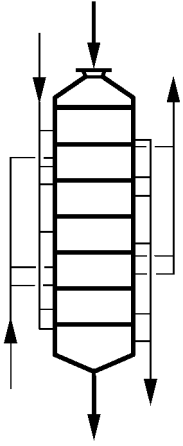
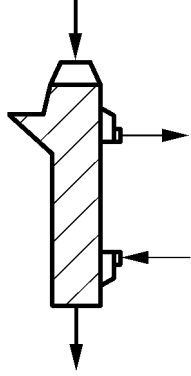
表 1 (续)

编 号	图形符号	中、英文名称	备 注
Y128		液压榨油机 hydraulic press	
Y129		小型螺旋榨油机 mini screw press	
Y130		螺旋榨油机 screw press, expeller	
Y131		双螺杆榨油机 two screw press	

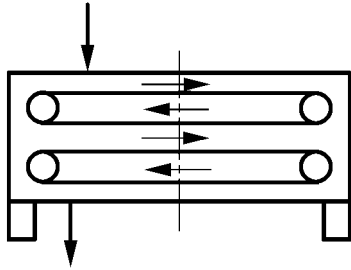
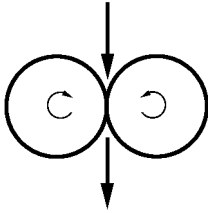
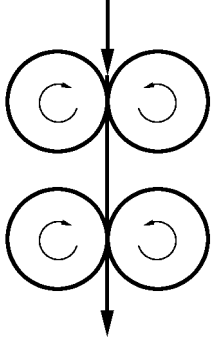
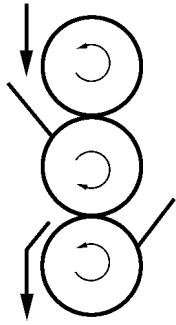
表 1 (续)

编 号	图形符号	中、英文名称	备 注
Y132		澄油箱/刮板澄油箱 clarifying tank	
Y133		振动式油渣分离器 vibratory oil residue separator	
Y201		封闭绞龙 sealed auger	
Y202		浸出罐 batch extractor	

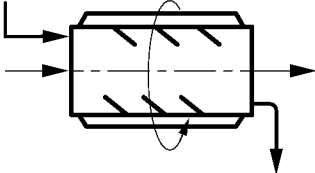
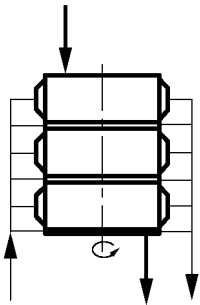
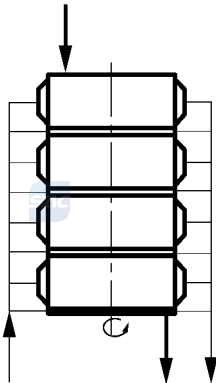
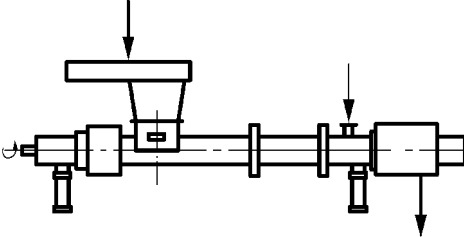
表 1 (续)

编 号	图 形 符 号	中、英文名称	备 注
Y203		平转浸出器 rotocel extractor	
Y204		履带浸出器 screen belt extractor	
Y205		环形浸出器 loop extractor	
Y206		履带-框式浸出器 belt-frame extractor	

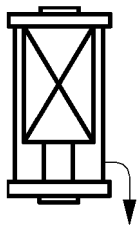
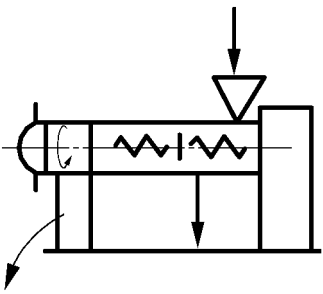
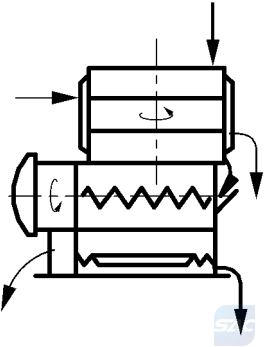
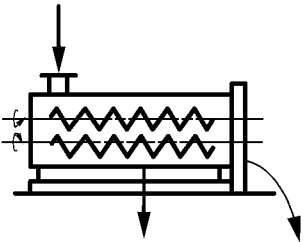
表 1 (续)

编 号	图形符号	中、英文名称	备 注
Y207		卧式蒸脱机 horizontal desolventizer toaster	
Y208		立式蒸脱机 vertical desolventizer toaster	
Y209		DT 蒸脱机 desolventizer toaster	
Y210		高料层蒸脱机 high bed desolventizer toaster	

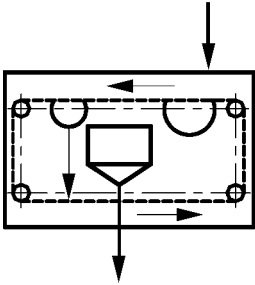
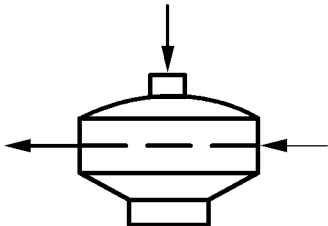
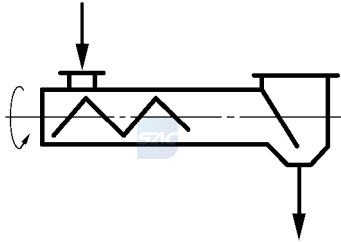
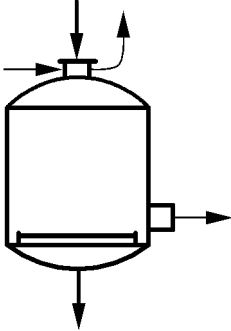
表 1 (续)



编 号	图形符号	中、英文名称	备 注
Y211		DTDC 蒸脱机 desolventizer toaster dryer cooler	
Y212		卧式低温脱溶设备 horizontal low temperature desolventizer	
Y213		粕冷却器 meal cooler	
Y214		湿式捕粕器 wet fines catcher 	

表 1 (续)

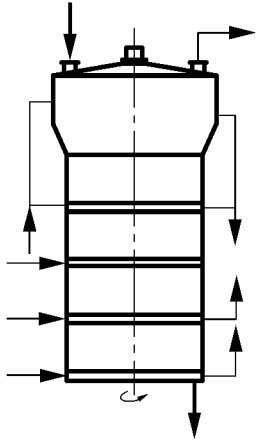
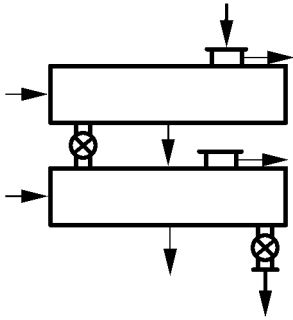
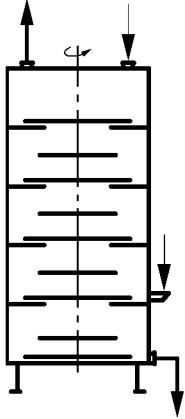
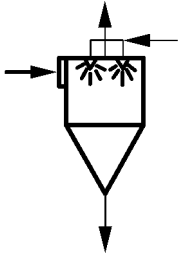

编 号	图形符号	中、英文名称	备 注
Y215		干式捕粕器 dry fines catcher	
Y216		旋液分离器 liquid cyclone	
Y217		混合油过滤机 miscella filter	
Y218		 长管蒸发器 raising film evaporator	
Y219		管式汽提塔 tubular stripping column	

表 1 (续)

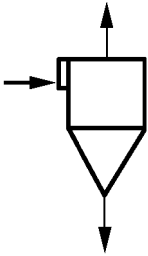
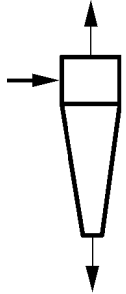
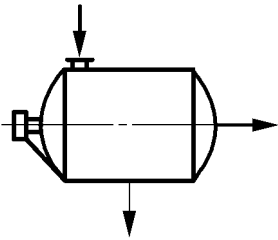
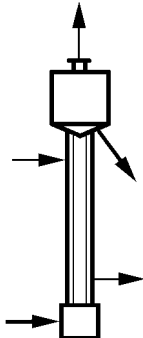

编 号	图形符号	中、英文名称	备 注
Y220		层碟式汽提塔 disc stripping column	
Y221		填料汽提塔 filling steam stripping column	
Y222		立式列管冷凝器 vertical pipe bundle condenser	
Y223		卧式列管冷凝器 horizontal pipe bundle condenser	

表 1 (续)

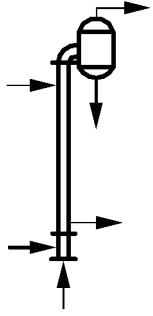
编 号	图形符号	中、英文名称	备 注
Y224		喷淋式冷凝器 spraying condenser	
Y225		大气冷凝器 atmospheric condenser	
Y226		综合溶剂罐 synthetical container	
Y227		分水器 solvent-water separator	

表 1 (续)

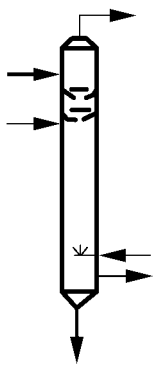
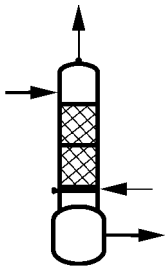
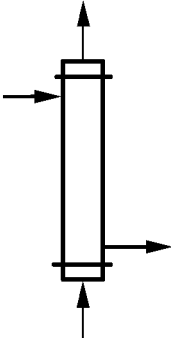
编 号	图形符号	中、英文名称	备 注
Y228		废水蒸煮罐 waste-water boiling tank	
Y229		填料吸收塔 packing absorbing column	
Y230		填料解吸塔 packing desorption column	
Y301		管道过滤器 on line strainer	

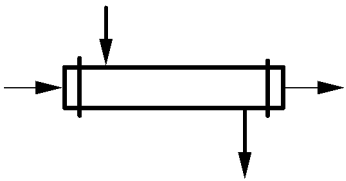
表 1 (续)

编 号	图形符号	中、英文名称	备 注
Y302		板框压滤机 plate-frame filter press 箱式压滤机 chamber filter press 冬化过滤机 wintering filter	
Y303		圆盘过滤机 disc filter	
Y304		碟式分离机 disc centrifugal separator disc centrifuge	
Y305		管式离心机 tubular bowl centrifuge	

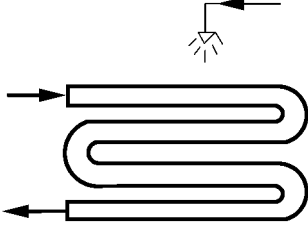
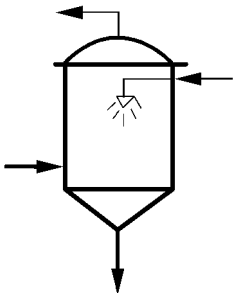
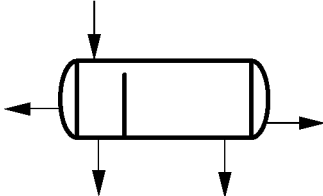
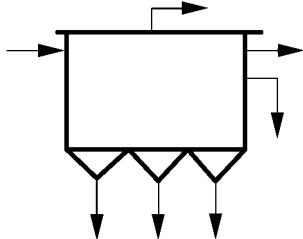
表 1 (续)

编 号	图 形 符 号	中、英文名称	备 注
Y306		卧式离心机 horizontal screw separator	
Y307		油碱配比器 proportion meter, oil and alkali dosing machine	
Y308		板式热交换器 plate heat exchanger	
Y309		螺旋板换热器 screw plate exchanger	

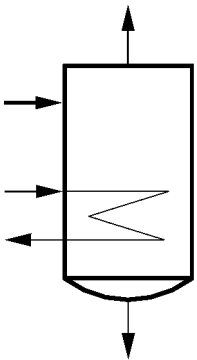
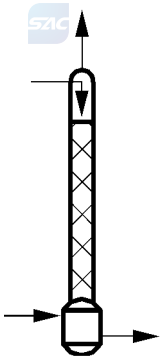
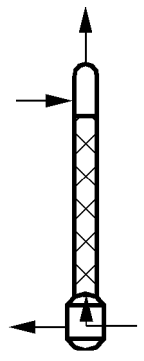
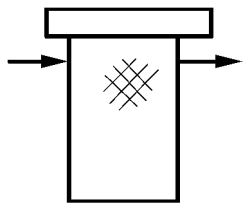
表 1 (续)

编 号	图形符号	中、英文名称	备 注
Y310		反应器 reactor	
Y311		静态混合器 static mixer	
Y312		盘式混合器 disc mixer	
Y313		卧式桨板混合机 horizontal paddle mixer	

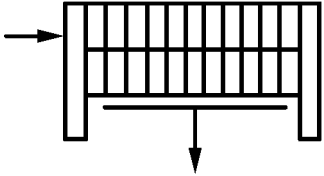
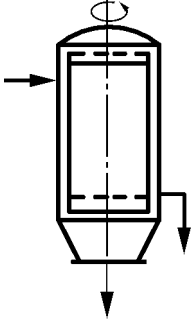
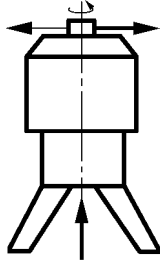
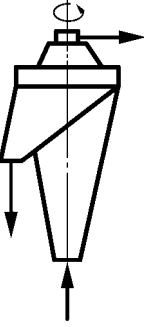
表 1 (续)

编 号	图形符号	中、英文名称	备 注
Y314		刀式混合器 blade mixer	
Y315		立式桨板混合机 vertical paddle mixer	
Y316		脱溶器 desolventizer	
Y317		真空干燥器 vacuum drier	

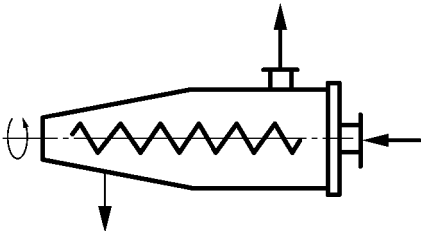
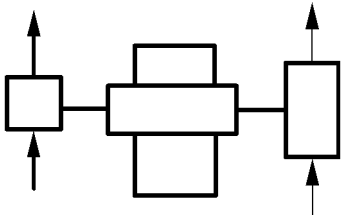
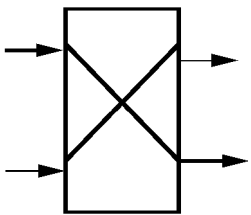
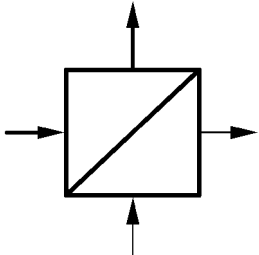
表 1 (续)

编 号	图形符号	中、英文名称	备 注
Y318		炼油罐 refining tank	
Y319		污油捕集器 dirty oil collector	
Y320		隔油池 separating oil pool	
Y321		皂脚罐/皂脚锅 soap stock tank	

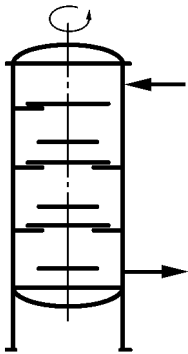
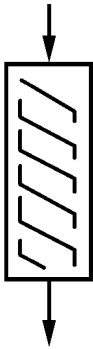
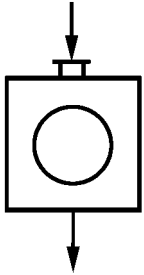
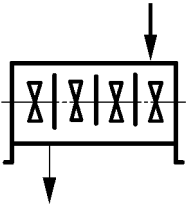
表 1 (续)

编 号	图形符号	中、英文名称	备 注
Y322		白土定量装置 bleaching earth dosing device	
Y323		脱色油预混合罐 decoloring premixing tank	
Y324		脱色罐/脱色锅 bleaching tank	
Y325		脱色塔 bleaching tower	

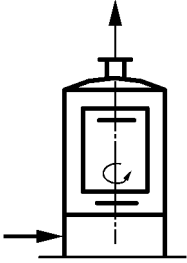
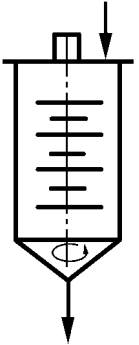
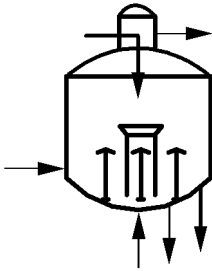
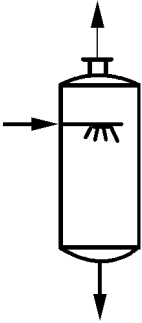
表 1 (续)

编 号	图形符号	中、英文名称	备 注
Y326		叶片过滤机 lamina filter	
Y327		袋式过滤器 bag filter, bag house filter 安全过滤器 safe filter	
Y328		析气器 deaerator	
Y329		脱臭罐 deodorizer	

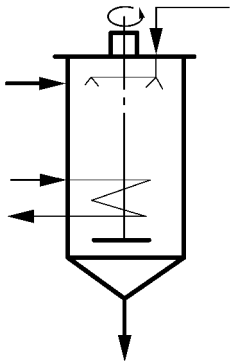
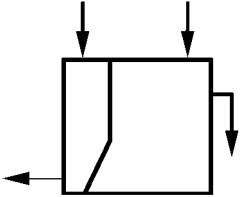
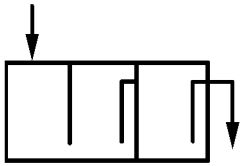
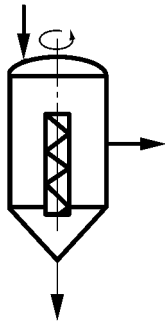
表 1 (续)

编 号	图形符号	中、英文名称	备 注
Y330		半连续脱臭器 semi-continuous deodorizer	
Y331		卧式脱臭器 horizontal deodorizer	
Y332		连续脱臭塔 continuous deodorizer	
Y333		填料式脱臭塔 filling deodorizing column 软塔 soft column	

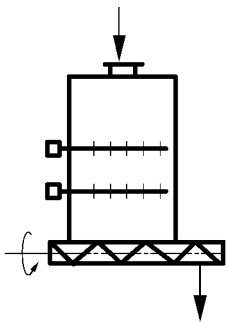
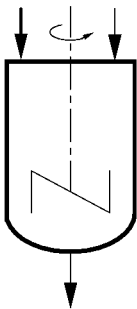
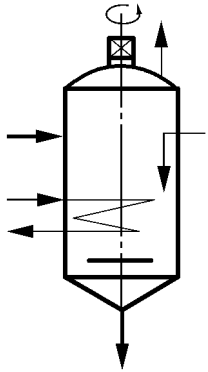
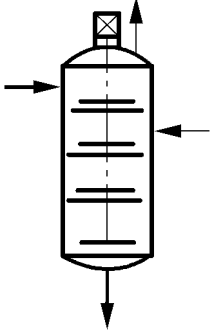
表 1 (续)

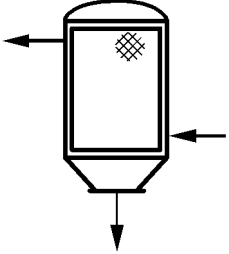
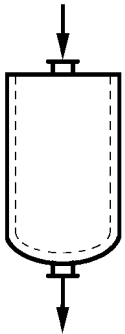
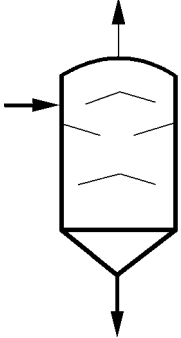
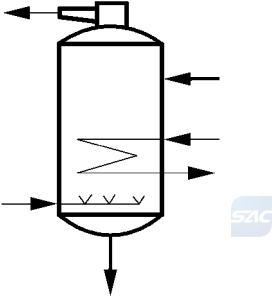

编 号	图形符号	中、英文名称	备 注
Y334		脂肪酸捕集器 fatty acid catcher	
Y335		高压锅炉 high pressure boiler	
Y336		导热油炉 conduction oil furnace	
Y337		水喷射真空泵 water ejector	

表 1 (续)

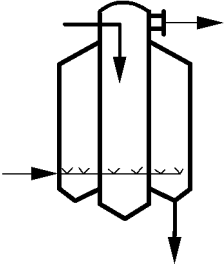
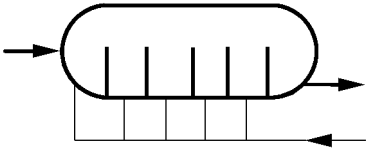
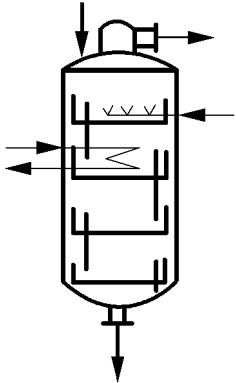
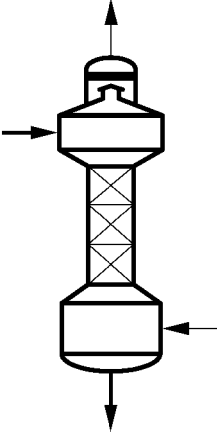
编 号	图形符号	中、英文名称	备 注
Y338		蒸汽喷射真空泵 steam ejector	
Y339		结晶罐 crystallizer	
Y340		养晶罐 maturing tank, maturator	
Y341		卧式叶片过滤机 horizontal lamina filter	

表 1 (续)

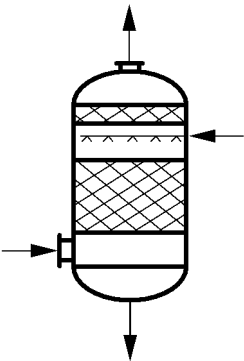
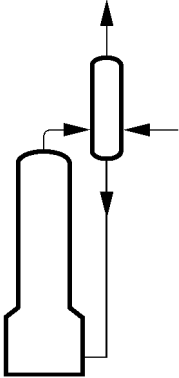

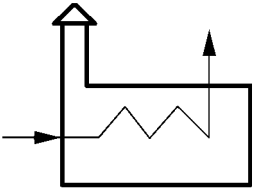
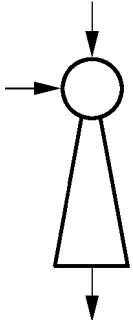
编 号	图形符号	中、英文名称	备 注
Y401		凉水塔 water cooling tower	
Y402		冷冻机 freezing machine	
Y403		蒸汽分配器 steam distributor	
Y404		汽水分离器 steam-water separator	
Y501		立式油棕果杀醇罐 vertical sterilizer	
Y502		卧式油棕果杀醇罐 horizontal sterilizer	

表 1 (续)

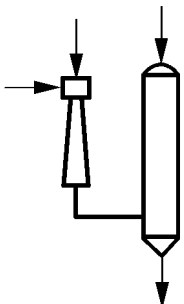
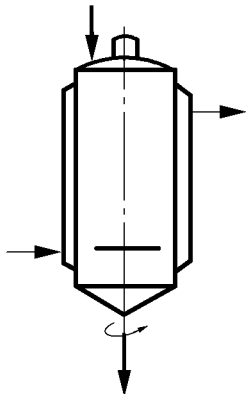
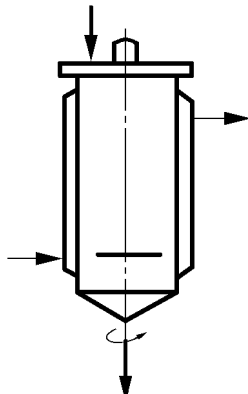
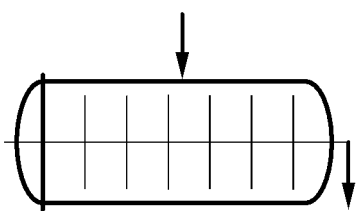
编 号	图 形 符 号	中、英文名称	备 注
Y503		棕果脱果机 thresher	
Y504		棕果捣碎罐 crasher	
Y505		棕榈油离心机 palm oil centrifuge	
Y506		核渣分离筛 palm nut screen	
Y507		核渣分离机 palm nut separator	

表 1 (续)

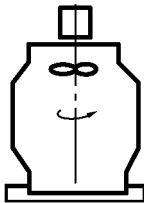
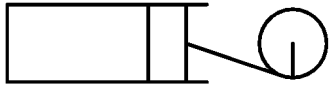
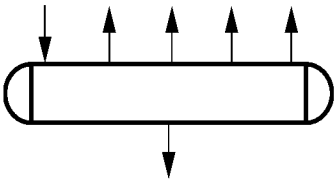
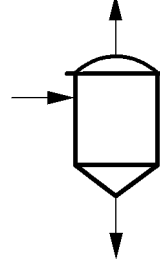
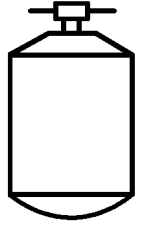
编 号	图形符号	中、英文名称	备 注
Y508		棕核壳仁分级圆筛 husk kernel reel	
Y509		转子式棕核壳仁泥水分离机 rotor type husk kernel separator	
Y510		刮板式棕核壳仁泥水分离机 chain conveying husk kernel separator	
Y601		截止阀 shut-off valve, stop valve	GB/T 6567.4—1986
Y602		角阀 angle valve, corner valve	GB/T 6567.4—1986
Y603		三通阀 tee valve, three-port valve, three way valve, triple valve	GB/T 6567.4—1986
Y604		止回阀 check valve, non-return valve	GB/T 6567.4—1986 流向由空白三角形 至非空白三角形

表 1 (续)



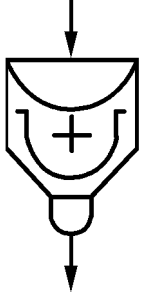
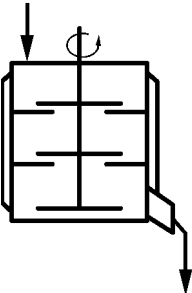
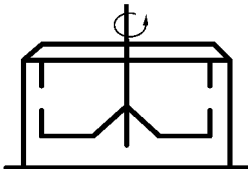
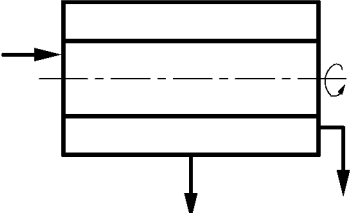
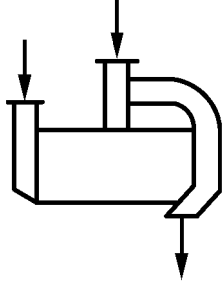

编 号	图形符号	中、英文名称	备 注
Y605		闸阀 gate valve	GB/T 6567.4—1986
Y606		电动调节阀 electric regulating valve	GB 4728.11—2000
Y607		球阀 ball valve, globe valve	GB/T 6567.4—1986
Y608		气动薄膜阀 pneumatic diaphragm valve	
Y609		蝶阀 butterfly valve	GB/T 6567.4—1986
Y610		气动蝶阀 pneumatic butterfly valve	
Y611		旋塞 cock	GB/T 6567.4—1986
Y612		三通旋塞 three-way cock	GB/T 4270—1999
Y613		减压阀 pressure reducing valve	GB/T 6567.4—1986 小三角形一端为高压端
Y614		压力调节阀 pressure regulating valve	

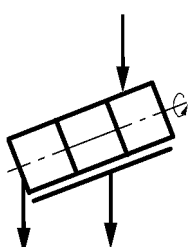
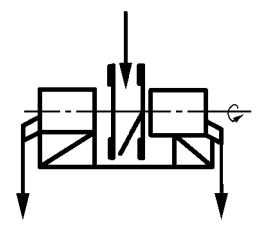
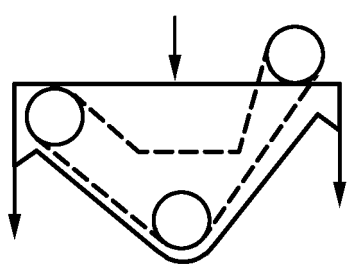
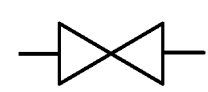
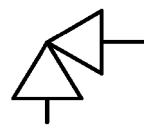
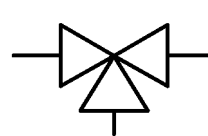
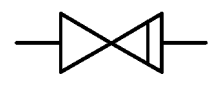
表 1 (续)



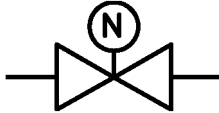

编 号	图形符号	中、英文名称	备 注
Y615		靶式流量变送器 target-type flowmeter	
Y616		弹簧安全阀 spring safety valve	GB/T 6567.4—1986
Y617		针形阀 needle valve	GB/T 6567.4—1986
Y618		隔膜阀 diaphragm valve	GB/T 6567.4—1986
Y619		四通阀 four way valve	GB/T 6567.4—1986
Y620		闭式弹簧安全阀 closed spring loaded safety valve	GB/T 6567.4—1986
Y621		开式弹簧安全阀 opened spring loaded safety valve	GB/T 4270—1999
Y622		闭式重锤安全阀 closed heavy hammer safety valve	GB/T 6567.4—1986
Y623		开式重锤安全阀 opened heavy hammer safety valve	GB/T 4270—1999

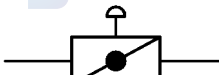
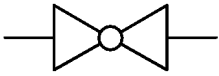
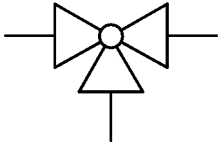
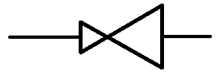
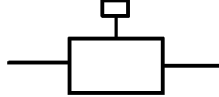
表 1 (续)



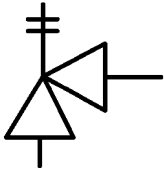
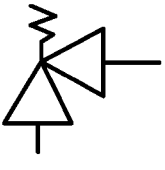
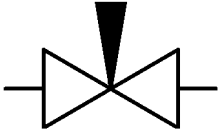
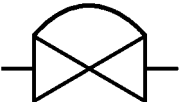
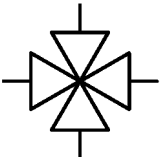

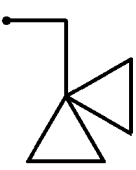
编 号	图形符号	中、英文名称	备 注
Y624		自力式压力控制阀 self acting pressure control valve	GB/T 2625—1981
Y625		底阀 bottom valve	GB/T 4270—1999
Y626		疏水阀 trainer valve trap	GB/T 6567.4—1986
Y627		水龙头 tap	
Y628		异径接头 increaser	
Y629		温度计 thermometer	
Y630		压力计 pressure gauge	
Y631		自动记录压力计 recording pressure gauge	
Y632		流量计 flowmeter	
Y633		自动记录流量计 recording flowmeter	

表 1 (续)



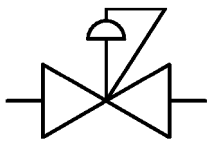
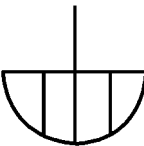
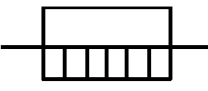
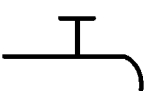
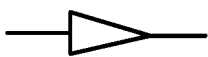

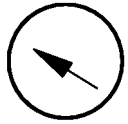
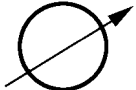

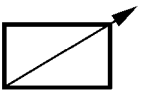



编 号	图形符号	中、英文名称	备 注
Y634		带过滤网的底阀 bottom valve(with filter)	
Y635		真空计 vacuum gauge	
Y701		油料、原料 oil bearing materials	
Y702		棉籽 cottonseed	
Y703		油菜籽 rapeseed	
Y704		大豆 soybean	
Y705		花生果 peanut	
Y706		芝麻 sesame	
Y707		米糠 rice bran	
Y708		棉籽仁 cottonseed kernel	

表 1 (续)

编 号	图形符号	中、英文名称	备 注
Y709	———— <i>SR</i> ————▶	花生仁 peanut kernel	
Y710	———— <i>KH</i> ————▶	葵花籽 sunflower seed	
Y711	———— <i>RF</i> ————▶	仁粉 kernel meal	
Y712	———— <i>K</i> ————▶	壳 husk	
Y713	———— <i>P</i> ————▶	坯 germ, embryo	
Y714	———— <i>B</i> ————▶	饼粕 cake or meal	
Y715	———— <i>Z</i> ————▶	油渣 oil residue	
Y716	———— <i>YJ</i> ————▶	油脚 oil sediment	
Y717	———— <i>ZJ</i> ————▶	皂脚 soapstock	
Y718	———— <i>HT</i> ————▶	灰土 dust	

表 1 (续)











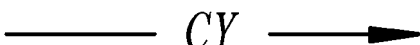
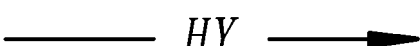

编 号	图形符号	中、英文名称	备 注
Y719		油 oil	
Y720		毛油 crude oil	
Y721		成品油 product oil	
Y722		混合油 miscella	
Y723		溶剂 solvent	
Y724		溶剂气 solvent vapour	
Y725		溶剂气+水蒸气 solvent vapour and steam	
Y726		溶剂+水 solvent and water	
Y727		尾气 exhaust gas/vent gas	
Y728		自由气体 solvent-carrying air	

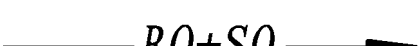
表 1 (续)

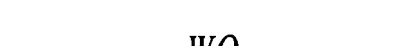
编 号	图形符号	中、英文名称	备 注
Y729		真空 vacuum	
Y730		冷冻液 cryogen, refrigerant	
Y731		导热油 conduction oil	

中文索引

A		对辊轧坯机	Y121
安全过滤器	Y327	多联打筛	Y103
B		F	
靶式流量变送器	Y615	反应器	Y310
白土定量装置	Y322	废水蒸煮罐	Y228
板框压滤机	Y302	分水器	Y227
板式热交换器	Y308	封闭绞龙	Y201
半连续脱臭器	Y330	G	
闭式弹簧安全阀	Y620	干式捕粕器	Y215
闭式重锤安全阀	Y622	高料层蒸脱机	Y210
饼粕	Y714	高压蒸汽炉	Y335
C		隔膜阀	Y618
层碟式汽提塔	Y220	隔油池	Y320
长管蒸发器	Y218	刮板式棕核壳仁泥水分离机	Y510
成品油	Y721	管道过滤器	Y301
澄油箱/刮板澄油箱	Y132	管式离心机	Y305
齿辊破碎机/剥壳机	Y113	管式汽提塔	Y219
锤式破碎机	Y115	H	
D		核渣分离机	Y507
大豆	Y704	核渣分离筛	Y506
大豆皮仁分离器	Y119	花生果	Y705
大豆调质塔	Y118	花生仁	Y709
大气冷凝器	Y225	环形浸出器	Y205
带式过滤网的底阀	Y634	灰土	Y718
袋式过滤器	Y327	混合油	Y722
刀板剥壳机	Y109	混合油过滤机	Y217
刀笼剥壳机	Y111	J	
刀式混合器	Y314	减压阀	Y613
导热油	Y731	胶辊磨泥机	Y106
导热油炉	Y336	角阀	Y602
底阀	Y625	绞笼式壳仁分离筛(螺旋筛)	Y116
电动调节阀	Y606	结晶罐	Y339
蝶阀	Y609	截止阀	Y601
碟式离心机	Y304	浸出罐	Y202
冬化过滤机	Y302		

静态混合器 Y311

K

开式弹簧安全阀 Y621
 开式重锤安全阀 Y623
 壳 Y712
 葵花籽 Y710

L

冷冻机组 Y402
 冷冻液 Y730
 离心剥壳机 Y110
 离心打泥机 Y107
 立式干燥机 Y117
 立式桨板混合机 Y315
 立式列管冷凝器 Y222
 立式软化锅 Y125
 立式油棕果杀酵罐 Y501
 立式蒸炒锅 Y126
 立式蒸脱机 Y208
 连续脱臭塔 Y332
 炼油罐 Y318
 凉水塔 Y401
 流量计 Y632
 履带浸出器 Y204
 履带-框式浸出器 Y206
 螺旋板换热器 Y309
 螺旋榨油机 Y130

M

毛油 Y720
 米糠 Y707
 棉籽 Y702
 棉籽仁 Y708

P

盘式混合器 Y312
 喷淋式冷凝器 Y224
 坯 Y713
 平板烘干机 Y120
 平转浸出器 Y203
 粕冷却器 Y213

Q

气动薄膜阀 Y608
 气动蝶阀 Y610
 汽水分离器 Y404
 球阀 Y607

R

仁粉 Y711
 溶剂 Y723
 溶剂+水 Y726
 溶剂气 Y724
 溶剂气+水蒸气 Y725
 软塔 Y333

S

三辊轧坯机 Y123
 三通阀 Y603
 三通旋塞 Y612
 湿式捕粕器 Y214
 疏水阀 Y626
 双对辊齿辊破碎机 Y114
 双对辊轧坯机 Y122
 双螺杆榨油机 Y131
 水龙头 Y627
 水喷射真空泵 Y337
 水洗机 Y105
 四通阀 Y619

T

弹簧安全阀 Y616
 填料解吸塔 Y230
 填料汽提塔 Y221
 填料式脱臭塔 Y333
 填料吸收塔 Y229
 脱臭罐 Y329
 脱溶器 Y316
 脱色罐 Y324
 脱色塔 Y325
 脱色油预混合罐 Y323

W

尾气 Y727

喂料锅	Y101	油料膨化机	Y127
温度计	Y629	油渣	Y715
卧式低温脱溶设备	Y212	圆盘剥壳机	Y108
卧式桨板混合机	Y313	圆盘过滤机	Y303
卧式离心机	Y306	圆筒打筛	Y102
卧式列管冷凝器	Y223		
卧式软化锅/卧式蒸炒锅	Y124	Z	
卧式脱臭器	Y331	皂脚	Y717
卧式叶片过滤机	Y341	皂脚锅/皂脚罐	Y321
卧式油棕果杀酵罐	Y502	闸阀	Y605
卧式蒸脱机	Y207	针形阀	Y617
污油捕集器	Y319	真空	Y729
X		真空干燥器	Y317
吸风平筛	Y104	真空计	Y635
析气器	Y328	振动式油渣分离器	Y133
箱式压滤机	Y302	蒸汽分配器	Y403
小型螺旋榨油机	Y129	蒸汽喷射真空泵	Y338
旋塞	Y611	DT 蒸脱机	Y209
旋液分离器	Y216	DTDC 蒸脱机	Y211
Y		芝麻	Y706
压力调节阀	Y614	脂肪酸捕集器	Y334
压力计	Y630	止回阀	Y604
养晶罐	Y340	转子式棕核壳仁泥水分离机	Y509
叶片过滤机	Y326	籽壳分离机	Y112
液压榨油机	Y128	自动记录流量计	Y633
异径接头	Y628	自动记录压力计	Y631
油	Y719	自力式压力控制阀	Y624
油菜籽	Y703	自由气体	Y728
油碱比配器	Y307	综合溶剂罐	Y226
油脚	Y716	棕果捣碎罐	Y504
油料、原料	Y701	棕果脱果机	Y503
		棕核壳仁分级圆筛	Y508
		棕榈油离心机	Y505

英文索引

A

angle valve, corner valve	Y602
atmospheric condenser	Y225
aspirated plan sifter	Y104
auger kernel husk separator	Y116

B

bag filter ,bag house filter, safe filter	Y327
ball valve, globe valve	Y607
bar-cage decorticator	Y111
bar huller	Y109
batch extractor	Y202
belt-frame extractor	Y206
blade mixer	Y314
bleaching earth dosing device	Y322
bleaching tank	Y324
bleaching tower	Y325
bottom valve	Y625
bottom valve(with filter)	Y634
butterfly valve	Y609

C

cake or meal	Y714
centrifugal decorticator	Y110
centrifugal soil bit impactor	Y107
chain conveying husk kernel separator	Y510
chain dryer	Y120
check valve, non-return valve	Y604
clarifying tank	Y132
closed heavy hammer safety valve	Y622
closed spring loaded safety valve	Y620
cock	Y611
conditioner	Y125
conduction oil	Y731
conduction oil furnace	Y336
continuous deodorizer	Y333
cottonseed	Y702
cottonseed kernel	Y708
crasher	Y504

crude oil	Y720
cryogen, refrigerant	Y730
crystallizer	Y339

D

deaerator	Y328
decoloring premixing tank	Y323
deodorizer	Y329
desolventizer	Y316
desolventizer toaster	Y209
desolventizer toaster dryer cooler	Y211
diaphragm valve	Y618
dirty oil collector	Y319
disc centrifugal separator	Y304
disc centrifuge	Y304
disc filter	Y303
disc huller	Y108
disc mixer	Y312
disc stripping column	Y220
dowtherm gas	Y732
dry fines catcher	Y215
dust	Y718

E

electric regulating valve	Y606
exhaust gas	Y727
expeller, screw press	Y130

F

fatty acid catcher	Y334
feeder	Y101
filling deodorizing column, soft column	Y333
filling steam stripping column	Y221
flowmeter	Y632
four way valve	Y619
freezing machine	Y402

G

gate valve	Y605
germ, embryo	Y713

H

hammer cracker	Y115
----------------------	------

high bed desolventizer toaster	Y210
high pressure boiler	Y335
horizontal conditioner	Y124
horizontal cooker	Y124
horizontal deodorizer	Y332
horizontal desolventizer toaster	Y207
horizontal lamina filter	Y341
horizontal low temperature desolventizer	Y212
horizontal paddle mixer	Y313
horizontal pipe bundle condenser	Y223
horizontal screw separator	Y306
horizontal sterilizer	Y502
hull and seed separator	Y112
hull beater	Y102
husk	Y712
husk kernel reel	Y508
hydraulic press	Y128

I

increaser	Y628
-----------------	------

K

kernel meal	Y711
-------------------	------

L

lamina filter	Y326
liquid cyclone	Y216
loop extractor	Y205

M

maturing tank, maturator	Y340
meal cooler	Y213
mini screw press	Y129
miscella	Y722
miscella filter	Y217
multiple hull beater	Y103

N

needle valve	Y617
--------------------	------

O

on line strainer	Y301
opened heavy hammer safety valve	Y623

opened spring loaded safety valve	Y621
oil	Y719
oil bearing materials	Y701
oil residue	Y715
oil sediments	Y716
oil seed expander	Y127

P

packing absorbing column	Y229
packing desorption column	Y230
paired flaking roll	Y121
palm nut screen	Y506
palm nut separator	Y507
palm oil centrifuge	Y505
peanut	Y705
peanut kernel	Y709
plate-frame filter press, chamber filter press, wintering filter	Y302
plate heat exchanger	Y308
pneumatic butterfly valve	Y610
pneumatic diaphragm valve	Y608
pressure gauge	Y630
pressure reducing valve	Y613
pressure regulating valve	Y614
product oil	Y721
proportion meter, oil and alkali dosing machine	Y307

R

raising film evaporator	Y218
rapeseed	Y703
reactor	Y310
recording flowmeter	Y633
recording pressure gauge	Y631
refining tank	Y318
rice bran	Y707
rotocel extractor	Y203
rotor type husk kernel separator	Y509
rubber roll soil bit mill	Y106

S

screen belt extractor	Y204
screw plate exchanger	Y309
sealed auger	Y201
sesame	Y706

self acting pressure control valve	Y624
semi-continuous deodorization tower	Y331
semi-continuous deodorizer	Y330
separating oil pool	Y320
shut-off valve, stop valve	Y601
soapstock	Y717
soap stock tank	Y321
soft column	Y334
solven	Y723
solvent and water	Y726
solvent carrying air	Y728
solvent vapour	Y724
solvent vapour and steam	Y725
solvent-water seperator	Y227
soybean	Y704
soybean conditioning tower	Y118
soybean hull seperator	Y119
spraying condenser	Y224
spring safety valve	Y616
static mixer	Y311
steam distributor	Y403
steam ejector	Y338
steam-water separator	Y404
sunflower seed	Y710
synthetical container	Y226

T

tap	Y627
target-type flowmeter	Y615
tee valve, three way valve, three-port valve, triple valve	Y603
thermometer	Y629
three-way cock	Y612
thresher	Y503
toothed cracking roll (one pair)	Y113
toothed cracking roll (two pairs)	Y114
toothed decorticator	Y113
trainer valve trap	Y626
triple flaking roll	Y123
tubular bowl centrifuge	Y305
tubular stripping column	Y219
two-paired flaking roll	Y122
two screw press	Y131

V

vacuum	Y729
vacuum drier	Y317
vacuum gauge	Y635
vertical cooker	Y125
vertical desolventizer-toaster	Y208
vertical dryer	Y117
vertical paddle mixer	Y315
vertical pipe bundle condenser	Y222
vertical stack cooker	Y126
vertical sterilizer	Y501
vibratory oil residue separator	Y133

W

washing machine	Y105
waste-water boiling tank	Y228
water cooling tower	Y402
water ejector	Y337
wet fines catcher	Y214

